

V9055A,D Modulating Fluid Power Gas Valve Actuator

PRODUCT DATA



APPLICATION

The V9055 Gas Valve Actuator in combination with a V5055, VE5000^a or V5097 Gas Valve provides modulating control of the gas supply to commercial and industrial burners.

FEATURES

- Actuator opens the valve to the low-fire position when energized. Actuator then modulates to meet firing rate controller (Series 90) demand.

- Actuator is equipped with an integral shaft that may be used to drive a combustion air damper in unison with the gas valve.
- The V5055 or V5097 Gas Valve includes a yellow SHUT indicator. The actuator includes a red OPEN indicator. The indicators provide constant visual indication of valve position.
- Actuator can be used with all VE5000^a, V5055 or V5097 Valve models; however, the V5055B or V5097B with characterized guide is recommended for optimum control and low-fire repeatability.
- Ambient temperature range for 60 Hz models is -40°F to 125°F (-40°C to 53°C). Ambient temperature range for 50 Hz and 50/60 Hz models is -10°F to 125°F (-23°C to 52°C).
- Auxiliary 1/2 hp rated switch is available for field installation.
- Integral damper shaft provides a maximum of 20 lb (9 kg) of force.
- Valve and actuator may be mounted in any position.
- Model is available with NEMA 4 (IP54) weatherproof enclosure.
- V9055D/V5055C,E and V9055D/V5097C,E combinations available with proof-of-closure switch and two valve seals (valve seal overtravel interlock) to meet specific code/standard/insurer requirements.
- Field addable adapter available for 4-20 dc mA control of actuator.
- When replacing a V9034 Actuator with a V9055, the V5034 Valve body must also be replaced with a V5055 or V5097 Gas Valve.

^a VE5000 is a European manufactured and approved valve for European use only.

Contents

Application	1
Features	1
Specifications	2
Ordering Information	2
Installation	4
Wiring	5
Adjustments	6
Operation	7
Checkout and Service	7



SPECIFICATIONS

Models:

V9055A: Modulating Fluid Power Gas Valve Actuator.

V9055D: Modulating Fluid Power Gas Valve Actuator with proof-of-closure switch.

Low-Fire Adjustment: 0.14 inch to 0.65 inch (with respect to V5055/V5097B Valve) valve stem travel. Refer to form 70-8311 for valve flow (capacity) curves.

Table 1. Pressure Ratings of Actuator-Valve Combinations.

Valve	Actuator	
	V9055 ^a	V9055D ^a (use with V5055C,E)
V5055B/V5097B 3/4 to 3 in.	5 psi (35 kPa) diff.; 15 psi (105 kPa) closeoff.	—
V5055B 4 in.	3 psi (21 kPa) diff.; 15 psi (105 kPa) closeoff	—
V5055A,C/V5097A,C 3/4 to 3 in.	5 psi (35 kPa) diff.; 15 psi (105 kPa) closeoff.	5 psi (35 kPa) diff.; 15 psi (105 kPa) closeoff.
V5055A,C 4 in.	3 psi (21 kPa) diff.; 15 psi (105 kPa) closeoff.	3 psi (21 kPa) diff.; 15 psi (105 kPa) closeoff.
V5055D,E/V5097D,E 3/4 to 1-1/2 in.	5 psi (35 kPa) diff.; 75 psi (525 kPa) closeoff.	5 psi (35 kPa) diff.; 75 psi (525 kPa) closeoff.
V5055D,E/V5097D,E 2, 2-1/2, 3 in.	5 psi (35 kPa) diff.; 45 psi (315 kPa) closeoff.	5 psi (35 kPa) diff.; 45 psi (315 kPa) closeoff.

^a The low-fire flow of the V5055/V5097A,C,D and E Valves will differ from those of the V5055/V5097B. Check the valve flow curves in form 70-8311 and match the low-fire adjustment to the burner design and application.

Table 2. Electrical Ratings.

Voltage/ Frequency	Opening		Holding	
	Watts	VA	Watts	VA
120/60	60	122	20	32
100-50/60	57/46	100/81	25/20	36/31
220/50	68	141	20	32
240/50	88	194	19	36

Table 3. Auxiliary and Proof-of-Closure Switch Ratings: 1/2 hp^a.

	120V	240V
Full Load	9.8A	4.9A
Locked Rotor	58.8A	29.4A

^a Maximum total connected power to both switches (if used) is 1800 VA.

Opening Time:

50 Hz models: 32 seconds (nominal).

60 Hz models: 26 seconds (nominal).

Closing Time: 1 second (maximum)

Damper Arm Rating (damper drives one direction only):

Standard Models: 20 lb. maximum at 2-11/16 in. radius at 20°F to 125°F and 5 lb at -40°F to 20°F (9 kg maximum at 68 mm radius at -7°C to 66°C and 2.3 kg at -40°C to -7°C).

Model with Damper Shaft Return Spring: 10 lb maximum at 2-11/16 in. radius at 20°F to 125°F and 5 lb at -40°F to 20°F (4.5 kg at 68 mm radius at -7°C to 66°C and 2.3 kg at -40°C to -7°C).

Damper Shaft: Shaft is 3/8 in. (9.5 mm) for use with 7616BR Damper Arm. Models available with damper shaft return spring.

ORDERING INFORMATION

When purchasing replacement and modernization products from your TRADELINE® wholesaler or distributor, refer to the TRADELINE® Catalog or price sheets for complete ordering number.

If you have additional questions, need further information, or would like to comment on our products or services, please write or phone:

1. Your local Honeywell Automation and Control Products Sales Office (check white pages of your phone directory).
2. Honeywell Customer Care
1885 Douglas Drive North
Minneapolis, Minnesota 55422-4386

In Canada—Honeywell Limited/Honeywell Limitée, 35 Dynamic Drive, Toronto, Ontario M1V 4Z9.

International Sales and Service Offices in all principal cities of the world. Manufacturing in Australia, Canada, Finland, France, Germany, Japan, Mexico, Netherlands, Spain, Taiwan, United Kingdom, U.S.A.

Ambient Temperature Rating:

-40°F to 125°F (-40°C to 52°C) for 60 Hz models, and
 -10°F to 125°F (-23°C to 52°C) for 50 Hz and 50/60 Hz models.

Mounting Means:

Actuator attaches directly to valve with two setscrews. Valve and actuator can be mounted in any position.

Installation Dimensions: See Fig. 1.

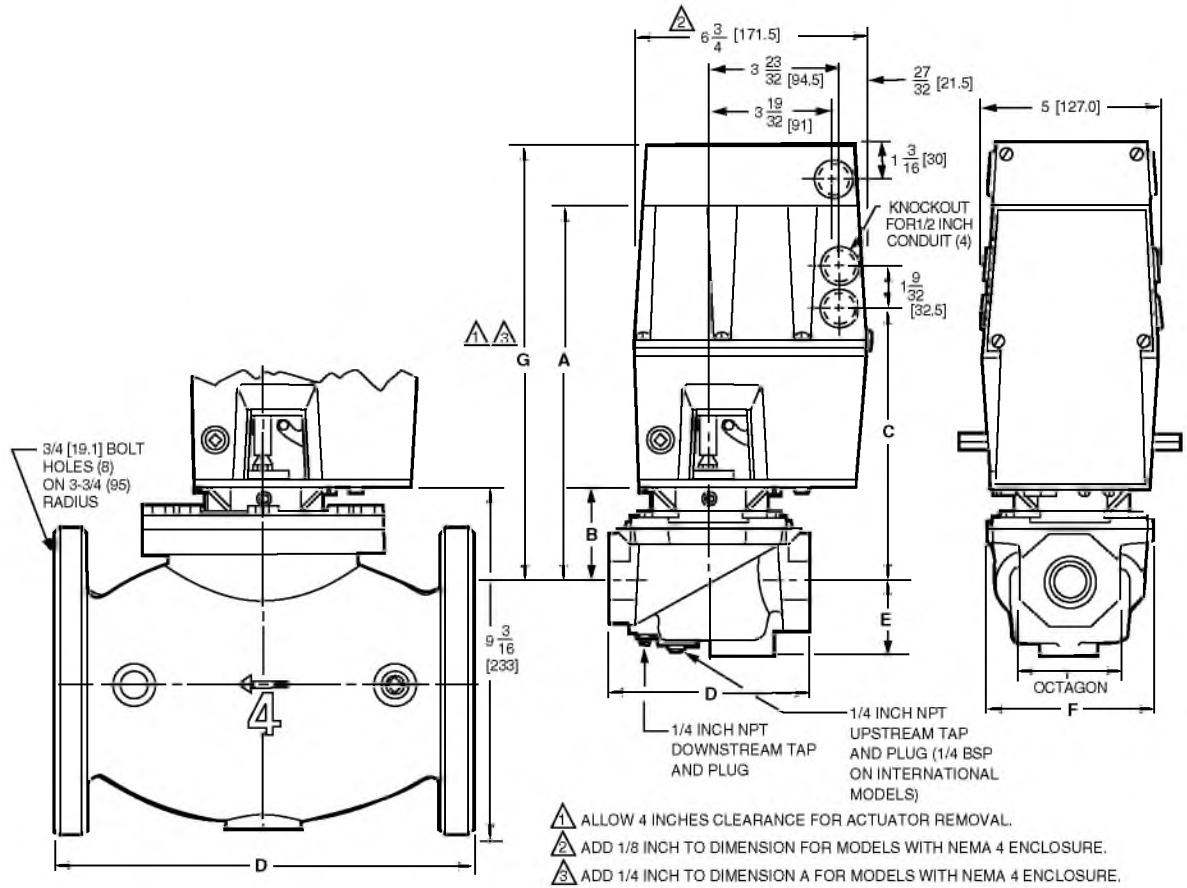

VALVE SIZE INCH	DIM A		DIM B		DIM C		DIM D		DIM E		DIM F		DIM G		OCTAGON	
	IN.	MM	IN.	MM	IN.	MM	IN.	MM	IN.	MM	IN.	MM	IN.	MM	IN.	MM
3/4	11-1/8	282.6	2-3/4	69.9	8-3/16	208.0	5-3/4	146.1	2-1/4	57.2	4-13/16	122.2	13-1/8	333.4	2-13/16	71.4
1	11-1/8	282.6	2-3/4	69.9	8-3/16	208.0	5-3/4	146.1	2-1/4	57.2	4-13/16	122.2	13-1/8	333.4	2-13/16	71.4
1-1/4	11-1/8	282.6	2-3/4	69.9	8-3/16	208.0	5-3/4	146.1	2-1/4	57.2	4-13/16	122.2	13-1/8	333.4	2-13/16	71.4
1-1/2	11-1/8	282.6	2-3/4	69.9	8-3/16	208.0	5-3/4	146.1	2-1/4	57.2	4-13/16	122.2	13-1/8	333.4	2-13/16	71.4
2	11-1/4	285.8	2-7/8	73.0	8-5/16	211.1	8-3/8	212.7	2-3/4	69.9	7-19/32	192.9	13-1/4	336.5	3-1/2	88.9
2-1/2	11-3/4	298.5	3-3/8	85.7	8-13/16	223.8	9-1/4	235.0	2-3/4	69.9	7-19/32	192.9	13-3/4	349.3	4-1/2	114.3
3	11-3/4	298.5	3-3/8	85.7	8-13/16	223.8	9-1/4	235.0	2-3/4	69.9	7-19/32	192.9	13-3/4	349.3	4-1/2	114.3
4	14-1/8	358.8	5-13/16	147.6	11-7/32	285.0	12-1/2	317.5	4-5/8	117.5	—	—	16-3/16	411.0	—	—

M7321

Fig. 1. V9055/V5055 dimensions in in. (mm).

NEMA 4 Enclosure: Model available.

Table 4. V9055/V5097 dimensions in in. (mm)

Valve Size ^a (in.)	Dim. A		Dim. B		Dim. C		Dim. D ^b		Dim. E		Dim. F		Dim. G		
	in.	mm	in.	mm	in.	mm	in.	mm	in.	mm	in.	mm	in.	mm	
Small Body	3/4	11-1/8	282.6	2-3/4	69.9	8-3/16	208.0	5-5/8	142.9	2-1/2	63.5	4-13/16	122.2	13-3/16	335
	1	11-1/8	282.6	2-3/4	69.9	8-3/16	208.0	5-5/8	142.0	2-1/2	63.5	4-13/16	122.2	13-3/16	335
	1-1/4	11-1/8	282.6	2-3/4	69.9	8-3/16	208.0	5-5/8	142.9	2-1/2	63.5	4-13/16	122.2	13-3/16	335
	1-1/2	11-1/8	282.6	2-3/4	69.9	8-3/16	208.0	5-5/8	142.9	2-1/2	63.5	4-13/16	122.2	13-3/16	336
	2	11-1/8	282.6	2-7/8	73.0	8-3/16	208.0	5-5/8	142.9	2-1/2	63.5	7-19/32	192.9	13-3/16	335.0
Large Body	2	11-3/4	298.5	3-3/8	85.7	8-3/8	212.7	9-7/16	239.7	4	101.5	7-19/32	192.9	13-3/8	339.7
	2-1/2	11-3/4	298.5	3-3/8	85.7	8-3/8	212.7	9-7/16	239.7	4	101.5	7-19/32	192.9	13-3/8	339.7
	3	11-3/4	298.5	3-3/8	85.7	8-3/8	212.7	9-7/16	239.7	4	101.5	7-19/32	192.9	13-3/8	339.7

^a Valve size using accessory pipe adapter fitting.

^b Without flanges.

Approvals:

Underwriters Laboratories Inc. Listed: File No. MN1639, Guide No. Y10Z.

Factory Mutual Approved: Report Nos. 20835 and 24061
International Approval Services (IAS), a joint venture of AGA and (CGA): Design Certified.

Industrial Risk Insurers: Acceptable.

Accessories:

133568 Auxiliary Switch.

7616BR Crank Arm.

135796 Wrench.

133569 Proof-of-closure Switch Bag Assembly. Must be used with V5055C or E.

203422C Adapter Board—Used to control V9055 Actuator with 4-20 dc mA input.

IMPORTANT

1. Do not attempt to use the V9055 with one of the adapters that connects the V4055 Actuator to the older V5034 Valves. The V9055 cannot be used with a V5034 Valve. When replacing a V9034 Actuator with a V9055, the V5034 Valve must be replaced with a V5055/V5097 Gas Valve.
2. Connect terminals R, W, and B only to Series 90 proportioning controller. Do not apply any voltage to these terminals.
3. Avoid mounting actuator upside down if water is likely to drip on it. In this position, water can become trapped in the electronics compartment.

INSTALLATION

⚠ WARNING

Electrical Shock Hazard.

Can cause serious injury, death or equipment damage.

1. Disconnect power before connecting wiring.
2. Assure that wiring complies with applicable electrical codes and ordinances.
3. Be sure that power supply is the same as that stamped on the nameplate of the device.
4. Be sure only a trained, experienced, flame safeguard control serviceman installs or services this device.
5. Assure that loads connected to the auxiliary switch, if used, do not exceed the ratings given in the Specifications section.

When Installing This Product...

1. Read these instructions carefully. Failure to follow them could damage the product or cause a hazardous condition.
2. Check the ratings given in the instruction and on the product to make sure the product is suitable for your application.
3. Installer must be a trained, experienced service technician.
4. After installation is complete check product operation as provided in these instructions.

Valve Installation

The actuator is mounted directly on the V5055/V5097 Valve after the valve is installed in the gas supply line. Refer to the instructions packed with the V5055/V5097 Valve for details of installation. When installing the valve, be sure that:

1. Sufficient clearance is left for installation and service of the actuator.
2. Ambient temperatures at the valve location will remain within the rated ambient range.
3. The position of the valve permits hookup to the damper if one is controlled.

IMPORTANT:

When a damper crank arm is used with a NEMA 4 actuator that is exposed to ice or sleet, a suitable shield must be installed to prevent ice or sleet buildup.

Install Accessory Switches (If Needed)

An spdt switch may be installed to operate an auxiliary load of up to 1/2 hp. The switch may be adjusted to operate at any point in the valve stroke. A proof-of-closure switch may also be installed. The proof-of-closure switch must be used with the V5055 C,E/V5097C,E (two seals) Valve to provide valve seal overtravel interlock.

The spdt proof-of-closure switch is installed to make or break a circuit when the valve is in the closed position. The switch is not adjustable.

NOTE: Mark the actuator or valve to indicate any changes made.

To install the switches, proceed as follows:

1. Remove the actuator faceplate (two screws).
2. Remove the silver-colored barrier to expose the actuator stem.
3. Insert the auxiliary switch in the position indicated in Fig. 3. Fasten with two screws through the actuator base.
4. Insert the proof-of-closure switch in the position shown in Fig. 3. The proof-of-closure switch mounts against the side of the actuator housing. The mounting holes are spaced to mount the switch only in the correct position. Fasten with two screws through the actuator base.
5. If only one switch is used, install the narrow barrier included with the switch in the unused space.
6. Mount the actuator before making wiring connections and adjustments to the switch.

Mount and Adjust Damper Crank Arm

IMPORTANT:

When a damper crank arm is used with a NEMA 4 actuator that is exposed to ice or sleet, a suitable shield must be installed to prevent ice or sleet buildup.

The crank arm provides a maximum travel of 2-5/16 in. (59 mm). For complete installation information, refer to the instructions packed with the 7616BR Crank Arm.

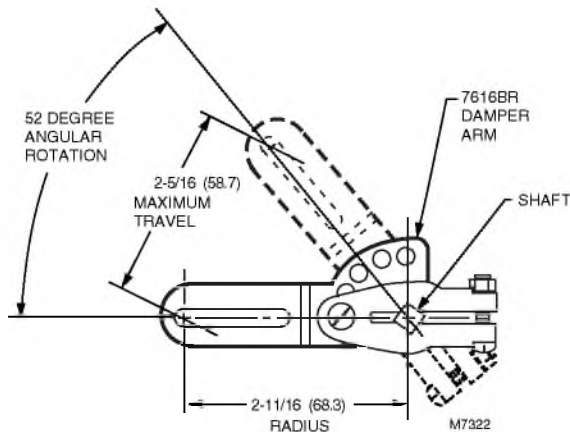

Fig. 2. Crank Arm Operation.

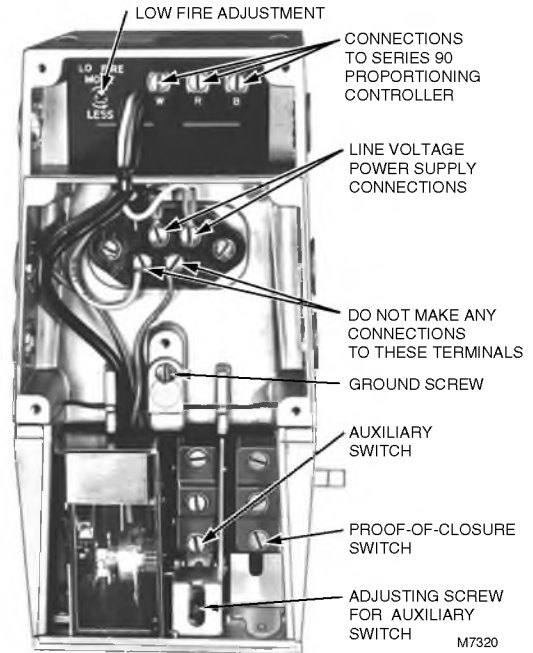

Fig. 3. Internal components and connections in V9055.

WIRING

⚠ WARNING

Electrical Shock Hazard.

Can cause serious injury, death or equipment damage.

To prevent electrical shock or equipment damage disconnect power supply before wiring.

All wiring must agree with applicable electrical codes and ordinances.

Connect power supply to terminals 1 and 2 on the terminal strip. Do not make any connections to the unmarked terminals shown in Fig. 3.

NOTE: When replacing a V9034, remove the 24 volt transformer because V9055 has a built-in transformer. When replacing a V9034 Actuator with a V9055, replace the V5034 Gas Valve with a V5055/V5097 Valve.

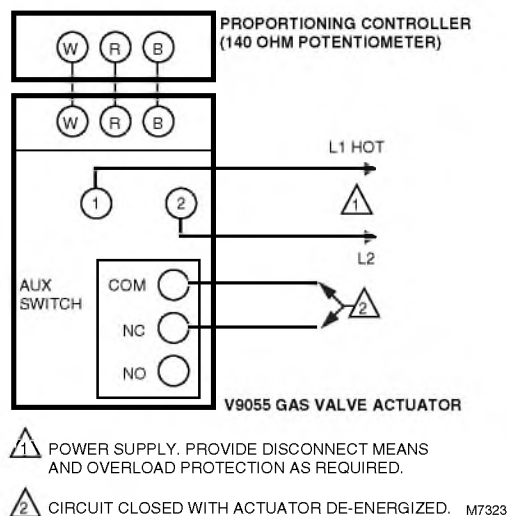

Fig. 4. Wiring for V9055 Modulating Gas Valve Actuator.

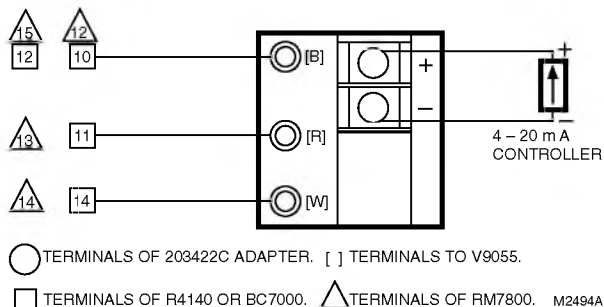

Fig. 5. Hookup of V9055 for firing rate control with a 4-20 mA input.

203422C—V9055 Adapter (For 4-20 mA Input) Installation

The 203422C Adapter Board allows the V9055 Modulating Fluid Power Gas Valve Actuator to be controlled with a 4-20 dc mA input. The adapter mounts in the wiring compartment and provides screw terminals for field wiring.

1. Remove the screws from terminals R,B and W on the V9055 Actuator.
2. Position the adapter board to the R, B and W terminals and install and tighten three screws (four screws provided in bag assembly) to the R, B, and W terminals.
3. Connect field wiring from 4-20 mA controller to the + and - terminals on the 203422C adapter board. Be sure to observe polarity.

CAUTION

Equipment Damage Hazard.
Incorrect wiring can damage the controller or adapter board.

Be sure to observe polarity from the controller to the 203422C Adapter Board.

4. Reconnect power.
5. With manual shutoff gas valve Closed, apply power to the V9055 and check its operations with the 4-20 mA temperature controller by manually incrementing and decrementing the output; 4 mA input will drive the V9055 to low-fire position; 20 mA drives to high-fire. Assure V9055 completes a full stroke.
6. Turn manual shutoff gas valve to the open position and test the remainder of the system for proper operation.
7. If the V9055 is being used for firing rate control, connect system according to the drawing in Fig. 5.
8. Sequence the burner through a normal startup.

CAUTION

Equipment Damage Hazard.

Improper wiring can cause equipment damage or danger to personnel.

Label all wires prior to disconnection when servicing valves. Wiring errors can cause improper and dangerous operation. Verify proper operation after servicing.

ADJUSTMENTS

IMPORTANT:



When using the V9055D with the V5055/V5097C or E (two seals) Valves, match low-fire minimum adjustment to the burner and the application. Too low of an adjustment could result in loss of burner flame. Also plan to check this low-fire adjustment at periodic maintenance intervals.

Adjust Low-Fire Setting

The low-fire setting is adjustable from approximately 0.14 to 0.65 inch valve stem travel (with respect to V5055B/V5097B Gas Valve). The low-fire adjustment is factory-set at the maximum position (approximately 50 percent of full gas flow capacity). Refer to form 70-8311 for valve flow (capacity) curves. Check to be sure the low-fire setting is at maximum (fully clockwise) before starting the adjustment procedure. To adjust:

1. Remove the lead to the V9055 terminal R. Jumper terminal R to W. This will prevent the actuator from going to the high-fire position.
2. Using a Phillips screwdriver, turn the low-fire adjusting screw to the desired low-fire position. Do not push inward on screw.
3. Shut down the burner, and then restart. Repeat several times to be sure the low-fire setting is suitable for correct burner lightoff.
4. Turn off power supply. Remove R-W jumper, and reconnect the lead to terminal R on the V9055.

Adjust the Auxiliary Switch (if used)

The auxiliary switch is adjustable throughout the stroke of the actuator. With the switch installed in the actuator, turn the adjusting screw (Fig. 3) clockwise  to cause the switch to operate earlier in the stroke and counterclockwise  to operate later in the stroke.

OPERATION

To function as intended, the V9055 must be connected to a properly sized valve. The proper sized V5055/V5097B Gas Valve with characterized guide is recommended for optimum control and low-fire repeatability. Too large of a valve will not properly modulate the gas flow. When the actuator is energized, it will drive at least to the adjusted low-fire position. The distance it will open beyond this low-fire position depends on the demands of the modulating controller.

When the controller calls for no heat, the actuator will modulate the valve to the low-fire position. When power to the actuator is interrupted, the valve will completely close.

Fig. 6 shows the V9055 in a typical flame safeguard control system.

CHECKOUT AND SERVICE

Checkout

IMPORTANT

Only a trained, experienced flame safeguard control technician should service or repair this control.

After the valve installation is complete, cycle the valve a few times with the manual fuel shutoff cock closed before testing the system in actual operation.

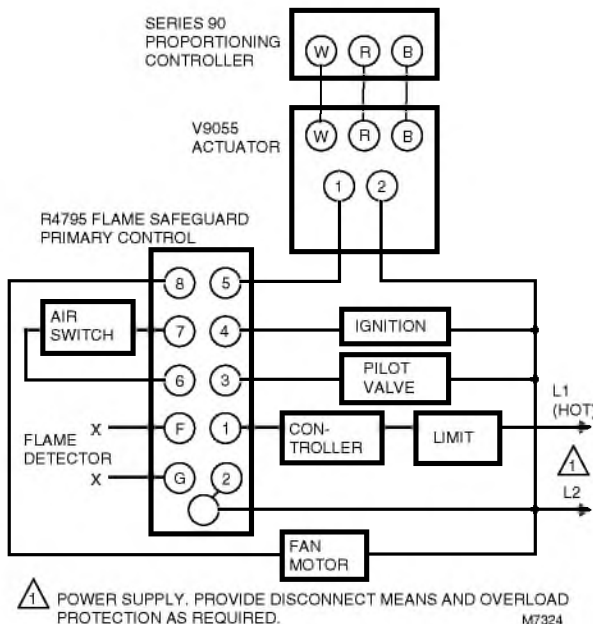

Fig. 6. V9055 connected to R4795 in typical application.

Service

The actuator is not field repairable except for replacing the auxiliary switch. See Install Accessory Switches section for the procedure.

Do not disassemble the valve actuator. Perform the following checks before removing and replacing the V9055 Gas Valve Actuator.

1. With manual gas valve closed, energize the V9055 and check for voltage on terminals 1 and 2. Actuator should modulate to the low-fire position.



CAUTION

Equipment Damage Hazard.

Improper wiring can damage the equipment and cause injury to personnel.

Label all wires prior to disconnection when servicing valves. Wiring errors can cause improper and dangerous operation. Verify proper operation after servicing.

2. Disconnect the leads from the modulating controller (terminals W,R, and B). Connect a manual potentiometer, color-to-color, to terminals W, R, and B on the actuator. With the valve energized, use the potentiometer to open and close the actuator. It should run from the low-fire position and to the fully open position.

If the actuator fails to operate properly, replace it.

1. Turn off the gas supply at the manual shutoff valve located upstream from the valve(s) being serviced.
2. Shut off all electrical power to the valve actuator(s).
3. Mark and disconnect the wires from the actuator terminals. Remove conduit and disengage the damper linkage assembly (if applicable).
4. Loosen the two set screws from the valve to lift off the actuator.
5. If the actuator is to be replaced and it did not leak hydraulic fluid, skip to Step 11.

NOTE: It is good practice to inspect the inside of the valve whenever the actuator is replaced. To do so, remove the bonnet assembly, inspect the valve and bonnet. If all is well, proceed to Step 7.

6. If the actuator leaked hydraulic fluid onto the valve (the fluid is red), it must be cleaned off from the valve and bonnet assembly.
 - a. Wipe off the outer valve body.
 - b. Remove the valve bonnet bolts and lift off the bonnet.

NOTE: V5055/V5097C and E Valves have additional internal springs that will push the bonnet up as the bolts are loosened.

- c. Inspect the inside of the valve.

IMPORTANT

If fluid is present on the inside surfaces of the valve body or bonnet surfaces, the bonnet assembly or entire valve must be replaced. See Table 5 below for the bonnet assembly part number.

- d. If the inside surfaces are clear of hydraulic fluid, clean the bonnet assembly and be sure to remove all hydraulic fluid from the inside and outside of the actuator mounting curb. This is the "cup-like" area around the valve stem. Avoid using a cleaning solution as it may damage the rubber seals used in the valve.

7. If the valve bonnet assembly is in good condition and is not replaced, replace the bonnet seal. Do not reuse the old bonnet seal. See Table 6 below for the seal number.
8. Coat seals with grease provided and position in valve body/bonnet assembly.
9. Carefully seat the bonnet assembly on the valve body. Be sure the seals are in their proper position. On those valves with a spring below the disc, be sure the spring is centered in the indentation on the inside of the valve body.
10. After positioning the bonnet assembly, replace the screws removed earlier.

NOTE: When replacing the bonnet assembly on the 4-inch valve, draw it evenly into the valve body. Finger-tighten the eight bolts. Draw the bonnet assembly into the valve by tightening, in order, bolts 1, 5, 7 and 3 (two turns each). Repeat until the bonnet assembly is seated. Tighten the remaining bolts. Torque the bolts as follows:

Valve Size	Torque
3/4 in. (19 mm) to 1-1/2 in. (38 mm)	55 in.-lb.
2 in. (51 mm) to 4 in. (102 mm)	75 in.-lb.

11. Remount the actuator on the bonnet assembly. Tighten the two set screws (50-60 inch pounds).
12. Replace the damper crank arm assembly.
13. Re-attach the wires removed from the actuator terminals and turn on the electrical power.
14. With the gas still off, cycle the actuator to check for proper mechanical operation.

CAUTION

Be sure to perform a bonnet seal and seat leak check after installation.

Be sure to read and follow all instructions that come with the actuators, valves, seal and bonnet kits.

Table 5. Replacement Bonnets for V5055/V5097 Gas Valves.

Replacement Bonnet	Valve		Valve Size (in in.)
133398AA	V5055A	V5097A	3/4, 1, 1-1/4, 1-1/2
133417AA			2, 2-1/2, 3
136911AA		(On-Off)	
133398BA	V5055B	V5097B	3/4, 1, 1-1/4, 1-1/2
133417BA			2, 2-1/2, 3
136911BA		(Characterized Guide)	
133398CA	V5055C	V5097C	3/4, 1, 1-1/4, 1-1/2
133417CA			2, 2-1/2, 3
136911CA		(Proof of Closure)	
136308AA	V5055D	V5097D	3/4, 1, 1-1/4, 1-1/2
136307AA			2, 2-1/2, 3
136308BA	V5055E	V5097E	3/4, 1, 1-1/4, 1-1/2
136307BA			2, 2-1/2, 3

Each replacement assembly contains the bonnet assembly, two rubber seals, and a tube of grease. It must be used only on the type of valve indicated above.

Table 6. Gas Valve Replacement Seals.

Replacement Seal Assy #	Valve Size (in in.)
133393A	3/4, 1, 1-1/4, 1-1/2
133392A	2, 2-1/2, 3
137253A	4

Automation and Control Solutions

Honeywell International Inc.
1985 Douglas Drive North
Golden Valley, MN 55422
customer.honeywell.com

Honeywell Limited-Honeywell Limitée
35 Dynamic Drive
Toronto, Ontario M1V 4Z9

Honeywell

