

# C7962B Visible Light Flame Detector

PRODUCT DATA



## FEATURES

- Used with 7800 SERIES Flame Safeguard controls.
- Used with R7851B Flame Amplifier.
- Has an integral collar threaded (internal 1/2-14 NPSM) for mounting on 1/2 inch sight pipe.

## APPLICATION

The C7962B Visible Light Flame Detector detects the visible light emitted by fuel oil combustion flames. The C7962B Detector is used with Honeywell Flame Safeguard controls to provide fuel oil flame supervision in commercial and industrial burners.

## Contents

Application .....	1
Features .....	1
Specifications .....	2
Installation .....	2
Ordering Information .....	2
Adjustments and Checkout .....	5
Troubleshooting .....	6
Maintenance .....	6



## SPECIFICATIONS

### Model:

C7962B Visible Light Flame Detector.

### Electrical Ratings:

#### Connections:

Two eight-foot (2.44 meters) color-coded NEC Class 1 leadwires.

### Environmental Ratings:

#### Ambient Operating Temperature:

-40°F to +165°F (-40°C to +74°C)

#### Storage Temperature Rating:

-20°F to +120°F (-29°C to +49°C).

#### Humidity:

90% relative humidity, noncondensing.

#### Vibration:

0.5G

### Maximum Pressure Rating:

5 psi.

### Mounting:

Collar with 1/2-14NPSM (internal thread) for mounting on a 1/2 inch sight pipe.

### Dimensions:

See Fig. 1.

### Accessory:

32007439-001 Mounting Bracket and screws.

118367A Swivel Mount.

### Approvals:

Underwriters Laboratories, Inc. listed: File No. MP268.

Factory Mutual (FM): Pending.

Canadian Standards Association (CSA): Pending.

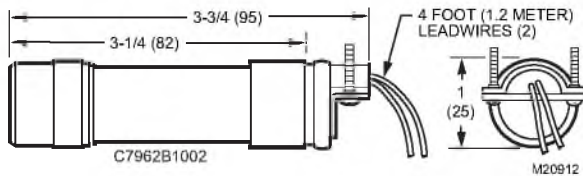

Fig. 1. C7962B Visible Light Flame Detector dimensions in in. (mm).

## ORDERING INFORMATION

When purchasing replacement and modernization products from your TRADELINE® wholesaler or distributor, refer to the TRADELINE® Catalog or price sheets for complete ordering number.

If you have additional questions, need further information, or would like to comment on our products or services, please write or phone:

1. Your local Honeywell Automation and Control Products Sales Office (check white pages of your phone directory).
2. Honeywell Customer Care  
1885 Douglas Drive North  
Minneapolis, Minnesota 55422-4386

In Canada—Honeywell Limited/Honeywell Limitée, 35 Dynamic Drive, Scarborough, Ontario M1V 4Z9.

International Sales and Service Offices in all principal cities of the world. Manufacturing in Australia, Canada, Finland, France, Germany, Japan, Mexico, Netherlands, Spain, Taiwan, United Kingdom, U.S.A.

## INSTALLATION

### ⚠ WARNING

#### Electrical Shock Hazard.

Can cause serious injury, death or property damage.

Disconnect power supply before beginning installation. More than one disconnect may be required.

### When Installing This Product...

1. Read these instructions carefully. Failure to follow them could damage the product or cause a hazardous condition.
2. Check the ratings given in the instructions and on the product to make sure the product is suitable for your application.
3. Installer must be a trained, experienced, flame safeguard control technician.
4. After installation is complete, check out product operation as provided in these instructions.

Disconnect the power supply before beginning installation to prevent electrical shock and equipment damage. All wiring must comply with applicable electrical codes, ordinances and regulations. Use NEC Class 1 (line voltage) wiring.

### ⚠ WARNING

#### Explosion Hazard and Electrical Shock Hazard.

Can cause serious injury, death or property damage.

1. The C7962B Flame Detectors must be used with Honeywell flame safeguard controls (primaries, programmers, multiburner systems, and burner management systems). Using with controls not manufactured by Honeywell could result in unsafe conditions.
2. Disconnect power supply before beginning installation to prevent electrical shock or equipment damage. More than one disconnect may be involved.
3. Read the installation instructions before starting the installation.
4. All wiring must be NEC Class 1 (line voltage).

## Basic Requirements for Flame Detector Installation

It is necessary for the detector to actually see the flame. Locate the detector as close to the flame as physical arrangement and temperature restrictions permit.

Sighting requirements for different types of flame supervision are:

1. Pilot flame only—Sighting must be along the axis of the pilot flame. The smallest pilot flame that can be sighted must be capable of igniting the main burner (see Pilot Turndown Test).
2. Main flame only—Sighting must be at the most stable part of the flame for all firing rates.
3. Pilot and main flame—Sighting must be at the junction of both flames.

## Mounting a C7962B Flame Detector

### Locate the Sight Pipe

The location of the sight pipe is the most critical part of the installation. A black iron pipe is recommended. Do not use a stainless steel or galvanized pipe because the internal surface blackens with use and deposits from the combustion chamber settle on it.

Under optimum conditions, the flame detector can detect most oil combustion flames at a distance of six feet (1.8 meters). The critical factors in determining the flame-detector distance separation are the optimized flame signal (current or voltage) and the flame detector temperature. Other factors may be influential and are associated with the specific installation. For minimum flame signals, see Table 1 and for ambient operating temperatures, refer to Specifications, page 2.

Use 1/2 inch pipe for a C7962B. Since no two situations are likely to be the same, length and sighting angle of the pipe must be determined at the time and place of installation. Generally, it is desirable to have the sight pipe tilting downward to prevent soot or dirt buildup.

If a C7962B is to be used for a blast tube installation, its location should be determined by the burner manufacturer. Contact the manufacturer before making any modifications to the installation.

### Prepare Hole in Wall of Combustion Chamber

Cut a hole of the proper diameter for the sight pipe in the wall of the combustion chamber at the selected location. Flare the hole to leave room for small adjustments of the sighting angle. The taper of the hole should be about 1 inch for every 3 inches (25 mm for every 76 mm) of wall thickness.

### Mounting the Sight Pipe (Fig. 2)

Thread one end of the pipe to fit the mounting collar on the detector. Cut the pipe to the desired length (as short as practicable) and at an angle so it fits flush with the wall of the

combustion chamber. Tack-weld the pipe to the wall in a trial position. Do not permanently weld the sight pipe in place until after completing the Adjustments and Checkout section.

NOTE: If you use a swivel mount (part no. 118367A) and you are positive about the location and sighting angle, you can permanently weld the pipe.

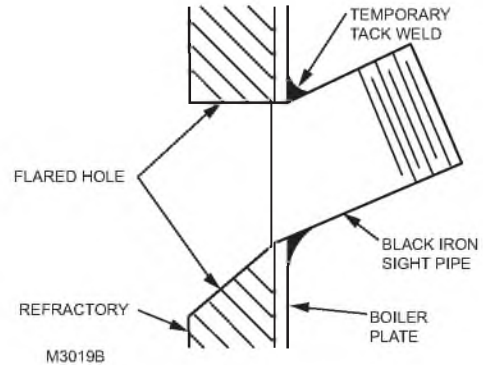

Fig. 2. Mounting sight pipe.

### Sight Pipe Ventilation

It may be necessary to ventilate the sight pipe to cool the flame detector or to clear the sight pipe of UV radiation absorbing material such as smoke, excessive moisture or, in some instances, unburned fuel.

For a negative pressure combustion chamber, drilling a few holes in the section of the sight pipe outside of the combustion chamber will allow air at atmospheric pressure to flow through the sight pipe into the chamber. A perforated pipe nipple between the sight pipe and the detector can also be used. (See Fig. 3.)

For a positive pressure combustion chamber, connect a supply of pressurized air from the burner blower through the sight pipe into the chamber. The supply air pressure must be greater than the chamber pressure.

### Swivel Mount

To facilitate proper sighting of the flame, a swivel mount (part number 118367A) is available. The swivel mount will require a 3/4 to 1/2 inch reducer and a 1/2 inch close nipple to mount a C7962B. For mounting details, refer to form 50-0361 for the 118367A Swivel Mount.

### Mount the Detector (Fig. 3)

Mount the detector onto the sight pipe, pipe tee, nipple, or other fitting. Make sure the flange gasket is in place inside the mounting collar on the detector, and then screw the collar onto the sight pipe or fitting.

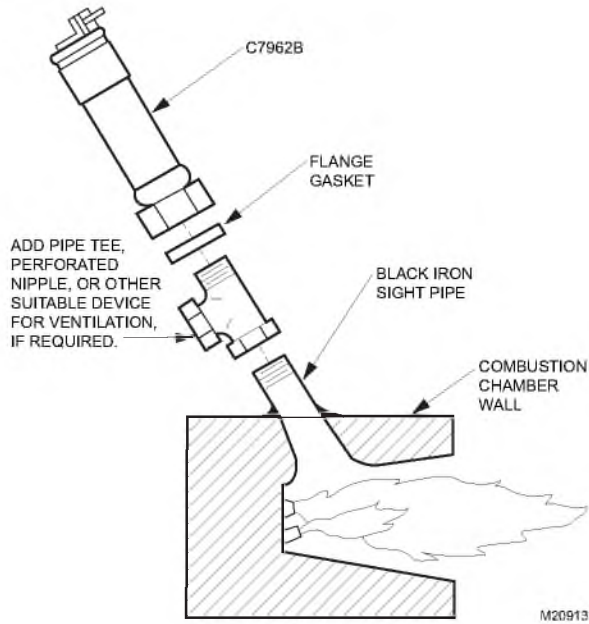

Fig. 3. Mounting a C7962B on a combustion chamber (viewed from above).

**Using a Heat Block with a C7962B (Fig. 4)**

If the temperature of the sight pipe will become high enough to cause the C7962B to overheat (above 165°F [74°C]) up to 266°F (130°C), screw a 136733 Heat Block (order separately) onto the sight pipe before mounting the detector.

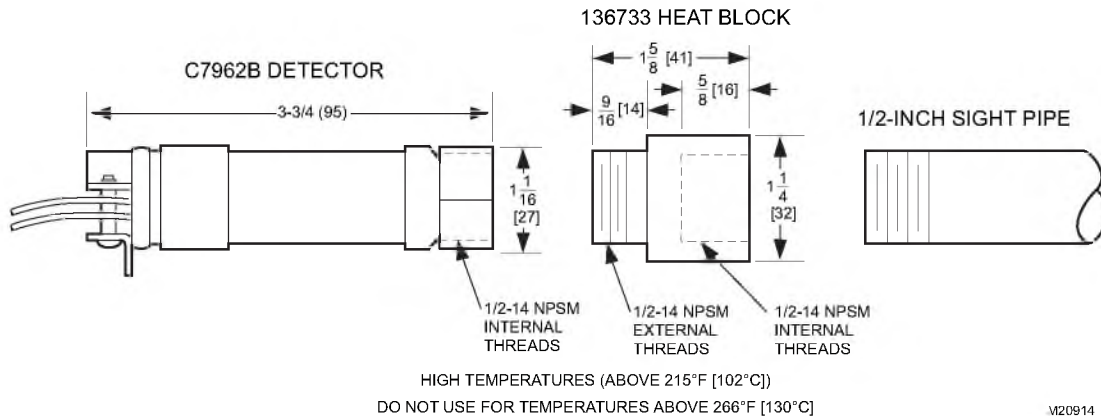

Fig. 4. Mounting dimensions of 136733 Heat Block in in. (mm).

**WIRING**

**CAUTION**

**Equipment Damage Hazard.  
Can cause improper operation.**

The blue leadwire must be connected to the F terminal of the flame safeguard control subbase or terminal strip and the white leadwire to the G terminal. Failure to observe the circuit polarity by reversing the leadwires (even momentarily) may cause the flame detector to improperly supervise the combustion flame.

**IMPORTANT**

*All wiring must comply with applicable local electrical codes, ordinances and regulations. Use NEC Class 1 (line voltage) wiring.*

The detector has color-coded and labeled, plastic-insulated, no. 18 AWG leadwires, eight ft. (2.44 m) long, rated for 221°F (105°C).

1. Keep the flame signal leadwires as short as possible from the flame detector to the terminal strip or wiring subbase. Capacitance increases with wire length, reducing the signal strength.

NOTE: The maximum permissible leadwire length depends on the type of leadwire and the conduit type and diameter. The ultimate limiting factor is flame signal leadwire length is the signal current or voltage at the flame safeguard device.

2. If needed, splice detector leadwires for longer leadwire runs, observing the following considerations:
  - a. Make required splices in a junction box.
  - b. Use moisture-resistant no. 14 wire suitable for at least 167°F (75°C).
  - c. For high temperature installation, use Honeywell Specification no. 32004766-003 or equivalent for the F leadwire. This wire is rated up to 400°F (250°C) for continuous duty. It is tested for operation up to 20 kV and for breakdown up to 35 kV. For the other leadwires, use moisture-resistant no. 14 wire selected for a temperature rating above the maximum operating temperature.
  - d. F and G wires must be run in their own conduit independent of other power carrying leadwires. More than one scanner F and G wire can be run in the same conduit.
  - e. A shielded twisted pair wire may be substituted for using conduit for routing the F leadwire. Be advised of the capacitance per foot of shielded wire effectively reduces the flame signal at the flame safeguard device. Be sure to ground the shield to the G terminal at the flame safeguard wiring subbase.
  - f. The detector wires need to be run in their own conduit as well, avoiding other electrical noise carrying wiring.
  - g. The scanner wires should remain separated a minimum of two in. (51 mm) from other line voltage wires in the main control panel to the flame safeguard device.
3. Avoid installation considerations that can influence detector operation and maximum leadwire length, such as:
  - a. Moisture.
  - b. Ignition interference.
  - c. High resistance connections—poor grounds.
  - d. Leadwire capacitance.
  - e. Voltage fluctuations.
  - f. Induced line transients.
  - g. Floating grounds—grounds at some voltage above earth ground.
  - h. No G wire—burner used as ground.
  - i. Detector output less than maximum attainable for the installation (inadequate sighting).

### IMPORTANT

*Do not run the flame detector wiring in the same conduit with high voltage ignition transformer wires.*

## Earth Ground

The detector and the flame safeguard control must be connected to earth ground. A convenient method of accomplishing this is to connect the detector to the flame safeguard control with a flexible conduit, or ensure a good ground connection at the mounting bracket.

## ADJUSTMENTS AND CHECKOUT

Before welding the C7962B sight pipe in its final location, or before tightening the C7962B, complete both the adjustments and checkout tests that follow and any required by the burner manufacturer.

### Adjust detector Sighting Position

With the flame detector installed and burners running, adjust the position of the flame detector for optimum flame signal. The flame signal will be read in voltage (Vdc).

The R7851B Amplifier used with the 7800 SERIES controls, has a dc voltage flame signal output.

For the R7851B Amplifier, a volt-ohmmeter with a zero to 5 of 10 Vdc scale and a minimum sensitivity of 1 megohm/volt is suggested. See Fig. 5.



**Fig. 5. Measuring flame signal voltage of 7800 SERIES controls.**

Measure the flame signal voltage as illustrated in Fig. 5. Be careful to connect the positive meter lead to the positive (+) amplifier jack and the negative meter lead to the negative (-) amplifier jack for a 7800 SERIES control. If the 7800 SERIES control has the optional Keyboard Display Module (KDM), a zero to five Vdc reading will be displayed on the KDM.

Move the flame detector and sight pipe (if not permanently attached to the burner/boiler) to view the flame from various positions. Allow a few seconds for the meter reading to stabilize. A maximum steady voltage reading is desirable. The flame signal must be above the minimum acceptable level for the flame safeguard control and associated amplifier.

Measure the flame signal for the pilot flame alone, the main burner flame alone, and both together (unless monitoring pilot only when using an intermittent pilot or supervising the main flame only when using direct spark ignition). Also, measure the flame signal at low and high firing rates and while modulating (if applicable).

With the flame detector in its final position, all flame signals must be steady with a voltage value as indicated for the device. If the minimum signal cannot be obtained or is unstable, refer to the Troubleshooting section.

## Pilot Turndown Test

If the detector is used to prove a pilot flame before the main fuel valve can be opened, perform a Pilot Turndown Test. Follow the procedures in both the instructions for the appropriate flame safeguard control and in the burner manufacturer instructions.

## Final Checkout

Before putting the burner into service, check out the installation using the procedures in the Checkout section of the instructions for the appropriate flame safeguard control. After completing the checkout, run the burner through at least one complete cycle to verify correct operation.

## TROUBLESHOOTING

### WARNING

**Electrical Shock Hazard.**  
**Can cause serious injury, death or property damage.**

Be extremely careful while troubleshooting the detector; line voltage is present on some of the terminals when power is on.

Open the master switch to disconnect power before removing or installing the detector.

### Inadequate Flame Signal

If a satisfactory flame signal cannot be obtained while adjusting the sighting position of the detector, perform the procedures indicated in steps 1 through 7, below. If other

difficulties are encountered in the system, refer to Troubleshooting in the instructions for the appropriate Honeywell flame safeguard control.

1. Check for proper line voltage. Make sure the master switch is closed, connections are correct, and power supply is the correct voltage and frequency.
2. Check the detector wiring for defects, including:
  - a. incorrect connections.
  - b. wiring type or size of wire.
  - c. deteriorated wire.
  - d. open circuits.
  - e. short circuits.
  - f. leakage paths caused by moisture, soot, or dirt.
3. With the burner running, check the temperature at the detector. When it exceeds 165°F (74°C):
  - a. use a heat block (part number 136733).
  - b. add the additional insulation between the wall of the combustion chamber and the detector.
  - c. add a shield or screen to reflect radiated heat away from the detector, or
  - d. add cooling (refer to Sight Pipe Ventilation).
4. Remove the detector and clean the viewing window with a soft, clean cloth.
5. Clean the inside of the sight pipe (if one is used) before reinstalling the detector.
6. If the flame signal continues to be too low, replace the plug-in amplifier (if the control has one).
7. If you still cannot obtain a proper flame signal, replace the C7962B Flame Detector.

### **IMPORTANT**

*At the completion of troubleshooting, be sure to perform the Adjustments and Checkouts.*

## MAINTENANCE

### Periodic Maintenance

1. Clean the viewing window and sight pipe (if used) when necessary. Remove the detector and use a soft, clean cloth to remove accumulated contaminants from the cell surface.
2. Replace the C7962B if it is damaged in any way.
3. Keep the flame detection system adjusted for the smoothest, most reliable operation as recommended by the burner manufacturer.



**Honeywell**

**Automation and Control Solutions**

Honeywell International Inc.	Honeywell Limited-Honeywell Limitée
1985 Douglas Drive North	35 Dynamic Drive
Golden Valley, MN 55422	Scarborough, Ontario
	M1V 4Z9

