

VR4700, VR8700, VR4705, VR8705

COMBINATION GAS CONTROLS FOR AUTOMATIC IGNITION SYSTEMS

INSTRUCTION SHEET

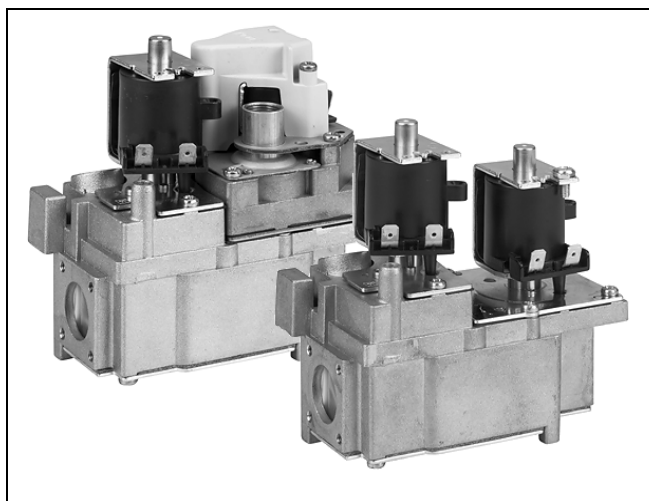

APPLICATION

VR4700, VR8700 and VR4705, VR8705 combination gas controls have been specifically developed for application in domestic and small commercial atmospheric gas appliances without a standing pilot. These controls are used in a system context conjunction with either a direct spark ignition (DSI) or intermittent pilot (IP) control module and associated devices to provide programmed safe light-up and supervision of the main burner of an appliance. They are intended to be used for manufactured, natural and LP gases (1st, 2nd, and 3rd family gas). Approved in accordance with existing European standards. The valves can withstand a backpressure of 50 mbar.

SPECIFICATIONS

Models

VR4700, VR4705 series:	220/240V ~ 50Hz; 220 V ~ 60Hz; 110V ~ 60Hz.
VR4710/VR4715 series:	220/240 V ~ 50Hz .
VR8700/VR8705 series:	24V ~ 50Hz; 24V ~ 60Hz.
VR8710/VR8715 series:	24V ~ 50Hz

Suffix A :	fast opening with regulator
Suffix C :	slow opening with regulator
Suffix D :	slow opening without regulator
Suffix E :	throttle - no pressure regulation

Pipe sizes

Inlet and outlet are made to receive the following size flanges
 Straight or elbow flanges with 1/2" BSP.PI internal parallel pipe thread .
 Straight or elbow flanges with 3/8" BSP.PI internal parallel pipe thread .
 Elbow flange with 1/2" ISO.R228 thread or mounting 15 mm O.D. tubing .
 Pilotgas connection : 4 mm or 6 mm O.D. tubing.
 Servo pressure regulator has M5 threaded hole to make connection between servo pressure regulator and combustion chamber of appliance (pressure feedback connection).

Capacity

MODEL	ΔP (mbar)	CAPACITY (m ³ /h)
VR4700/VR4705A,C VR8700/VR8705A,C	3	2.1
VR4700/VR4705E VR8700/VR8705E	2.5	1.9
VR4710/VR4715A,C VR8710/VR8715A,C	4	1.9

Minimum regulation capacity

Suffix A, C: 0,3 m³/h air.

Ambient temperature

0 . . . 70°C

Maximum operating pressure

Suffix A, C :
 30 mbar for adjustable pressure range of 2...20 mbar .
 37 mbar for adjustable pressure range of 3...20/37 mbar .
 60 mbar for adjustable pressure range of 8...50 mbar .

Suffix D, E : 60 mbar .

Regulator output pressure range

Suffix A, C: 2 . . . 20 mbar for Nat/Mfd gas
 3 . . . 20/37 mbar for Nat/Mfd. gas*
 8 . . . 50 mbar for Nat/LP gas

* This type can also be used for non regulating mode in LP gas applications.

Adjustment range of throttle valve

At a 50 mbar inlet pressure the valve can be adjusted from 0,2 m³/h flow of air to full open .

Screen and pilot filter

At inlet side of the control an internal fine woven wire screen is provided .

Screen and pilot filter are both accessible by removing the bottomplate of control . (See fig . 5)

Mounting holes

Two M4 mounting holes are located on the bottom of the control . The four holes for mounting the flange on the control are provided with M4 thread with min. 6,5 mm full thread .

Electrical data

Power consumption (W)

Working voltage	1st operator		2nd operator	
	spade	connector faced	suffix A,C,D	suffix E
24V ~ 50 Hz	3,5	-	3,3	3,5
220V ~ 50 Hz	3,6	4,5	2,6	3,6
240V ~ 50 Hz	3,7	4,2	3,3	3,7
24V ~ 60 Hz	4,9	-	2,7	4,9
110V ~ 60 Hz	5,0	-	3,0	5,0
220V ~ 60 Hz	4,9	-	2,2	4,9

Current (mA)

Working voltage	1st operator		2nd operator	
	spade	connector faced	suffix A,C,D	suffix E
24V ~ 50 Hz	280	-	200*	280*
220V ~ 50 Hz	32	40	18	32
240V ~ 50 Hz	29	32	20,5	29
24V ~ 60 Hz	402	-	180	402
110V ~ 60 Hz	92	-	42	92
220V ~ 60 Hz	44	-	15,9	44

* Adjust heat anticipator of thermostat (if applicable) to this value

Enclosure (including cover)

IP 40

Valve classification

MODEL	1st valve	2nd valve
VR4700/VR4705A,C VR8700/VR8705A,C	Class B	Class D
VR4700/VR4705E VR8700/VR8705E	Class B	Class B
VR4710/VR4715A,C VR8710/VR8715A,C	Class B	Class C

valve classification according EN161

Closing time

Class B: < 1s.
Class C: < 1s.
Class D: < 2s.

Add-on components and accessories

(to be ordered separately)

Overall cover with screw and conduit plate.

Suffix A, C, D: 45.900.401-010 (200)
45.900.401-019 (10)
45.900.401-014 (200)

Suffix E : 45.900.401-008 (200)

Conduit cover with screw.

Suffix A, C, D, M, N, P, Q
side outlet 45.900.401-015 (200)
45.900.401-017 (10)
end outlet 45.900.401-016 (200)
45.900.401-018 (10)

Number between bracket indicates packing quantity.

Pilot outlet compression fittings:

PILOT OUTLET OUTSIDE DIAMETER	ORDER NUMBER
4 mm	45.900.402-003
6 mm	45.900.402-002

Straight flange assemblies:

FLANGE SIZE	ORDER NUMBER
3/8"	45.900.400-101**
1/2"	45.900.400-102** 45.900.400-106

Elbow flange assemblies:

FLANGE SIZE	ORDER NUMBER
3/8"	45.900.400-103**
1/2"	45.900.400-104** 45.900.400-108

** include 'O'-ring and screws.

INSTALLATION

IMPORTANT

Installer must be a trained, experienced serviceman.

Turn off gas supply before starting installation

Disconnect power supply to prevent electrical shock and/or equipment damage

Do not remove seals over control in- and outlet until device is ready to be installed

Mounting positions

The combination gas controls can be mounted 0 to 90 degrees in any direction from the up right position i.e. from the position when solenoids are on top .

Main gas connections

1. Use a sound taper pipe fitting with thread according to BS21 or a piece of new, properly reamed pipe, free from swarf.
2. Do not thread or tighten pipe or pipe fitting too far (see table below). Otherwise flange distortion and malfunction could result.

PIPE SIZE (inch)	MAX. LENGTH OF PIPE THREAD (mm)
3/8	14
1/2	18,6

3. Apply a moderate amount of good quality thread compound to pipe or fitting only, leaving the two ends threads bare. PTFE tape maybe used as an alternative.
4. Tighten the pipe to flange and mount flange to control afterwards.
5. Ensure that "O"-ring is properly placed in groove of flange.
6. Ensure that gas flow is in same direction as arrow on the bottom of valve.

Main gas connection 15 mm O.D. tubing.

1. Square off end of tubing and remove burrs.
2. Slip and gland and ferrule over tubing.

3. Insert tubing in to the flange until it bottoms, slide ferrule and gland into place and turn finger tight.
Do not use jointing compound.
4. Use a wrench to tighten gland about one turn beyond finger tight.

Pilot gas connection (VR4700/VR8700)

1. Square off end of tubing and remove burrs.
2. Slip compression fitting over tubing. Insert tubing into gas valve housing until it bottoms, slide compression fitting in to place and turn finger tight.
3. Use a wrench to tighten fitting about 1/2 turn beyond finger tight to shear off olive. Do not use jointing compound.
4. Connect other end of tubing to pilot burner, according to the pilot burner manufacturer's instructions.



CAUTION

Do not bend tubing at control after compression fitting has been tightened, as this may result in gas leakage at the connection

Mind that length of pilot burner connection and pilot burner characteristics have influence on time to ignite the pilot burner. This can interfere with available ignition timings.

Electrical connections



CAUTION

Switch off power supply before making electrical connections.

Never jumper the terminals of lower voltage gas valves since this may burn out the room thermostats heat anticipator.

Wiring must be in accordance with local regulations

To ensure a safely closing of the valve, it is essential that voltage over the terminals of operator is reduced to 0 volt. **Mind that cut-off function of limit control de-energizes both valves.**

Use leadwire which can withstand 105°C ambient.

Operator can be provided with:

- Quick connect terminals suitable for 6.3 mm receptacles (e.g. "series 250" AMP fasteners)

Pressure tap

The control is provided with a pressure tap of 9 mm O.D. at in- and outlet. When checking pressure undo screw a half turn and slip tube over nipple. Ensure that screw is retightened after making test.

Pilot flame adjustment (VR4700/VR8700)

Control is packed for shipment with pilotflow at maximum . Refer to pilot burner or appliance manufacturer's instructions for recommended size of pilotflame .

If adjustment is required turn pilot adjustment screw (see fig. 3 and 4) clockwise to decrease or counter-clockwise to increase pilot flame. It should be noted , that after a long time of stop page (summer) it can take up to 60s to come ignition of the pilot burner .

Outlet pressure adjustment, suffix A, C. (see fig. 3)

1. Solenoid operators must be energized in order to have gas input to burner.

2. Check input to appliance using a clocking gas meter or alternatively a pressure gauge connected to outlet pressure tap.
3. Remove cap screw to expose pressure regulator adjustment screw.
4. Disconnect pressure feedback connection (if applicable).
5. Using a screwdriver, slowly turn adjustment screw until required burner pressure is recorded on pressure gauge. Turn adjustment screw clockwise to increase and counter-clockwise to decrease gas pressure to burner.
6. For non regulating mode (LP gas) turn adjustment screw clockwise until it stops.
7. Replace pressure regulator cap screw.
8. Reconnect pressure feedback connection (if applicable).
9. Replace cover.

Check of slow opening

Slow open pressure is factory set. Check burner performance at this pressure observing burner ignition and flame characteristics. Burner should ignite promptly and without flash back to orifice and all ports should remain lit . Cycle burner several times (wait 15 seconds between cycles to allow servo-system to resume slow open action). Repeat after allowing appliance to cool - down .

Gas flow adjustment, suffix E (see fig. 4)

1. Solenoid operators must be energized in order to have gas in put to burner.
2. Check input to appliance using a clocking gasmeter or alternatively a pressure gauge connected to outlet pressure tap.
3. The gasflow to burner can be adjusted using throttle flow adjustment screw. Using a screwdriver, slowly turn throttle flow adjustment screw clockwise to decrease and counterclockwise to increase gasflow to burner.
4. Replace cover.

Checkout

Before leaving, set appliance in operation and observe through a complete cycle to ensure that burner system components function correctly.

SERVICE

Cleaning screen

Control is provided with a fine woven screen on inlet side which is easily accessed for cleaning by removing bottom plate (see fig. 5).

Replacing pilot filter. VR4700/VR8700

Pilot filter is accessed exactly as is the screen (see fig. 5).

IMPORTANT

After mounting bottom plate, control must be checked for leakage.

NOTE

In case of dismantling and remounting flanges:
Though by careful handling the "O"-ring could be re-used when is undamaged, it is advised to use a new "O"-ring (order number 45.900.405-001) to be sure to have a reliable tight connection

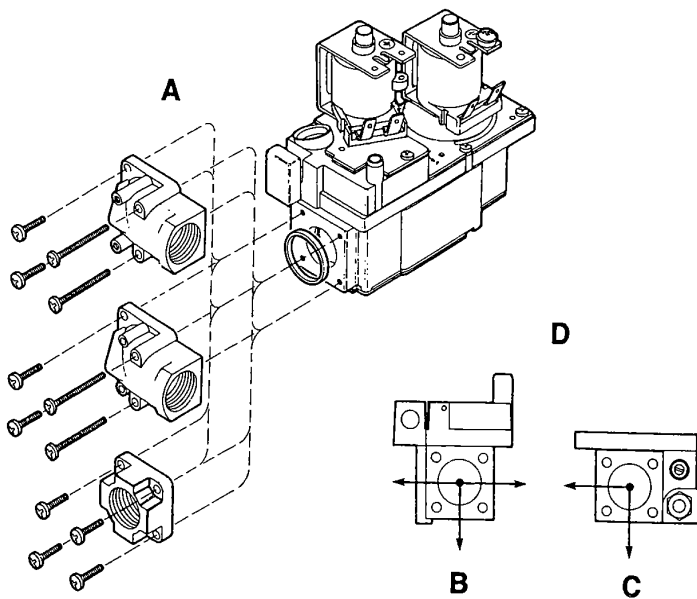

- A installing aids: specially useful where it is necessary to quickly and easily install and remove the combination gas control from the pipe run
- B Inlet side
- C Outlet side
- D Possible position of elbow flanges

Fig. 1.

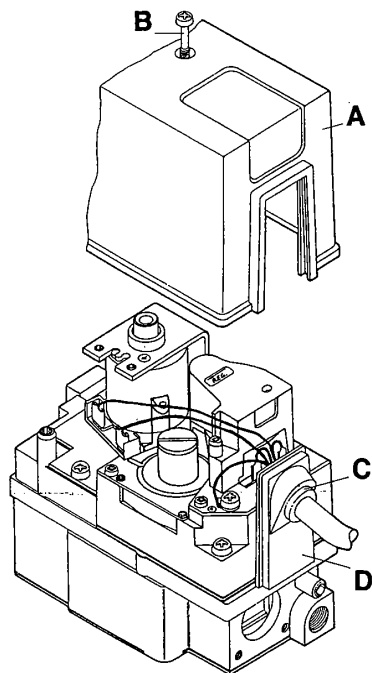

- A Cover
- B Cover retaining screw
- C Heyco strain relief
- D Conduit plate

Fig. 2.

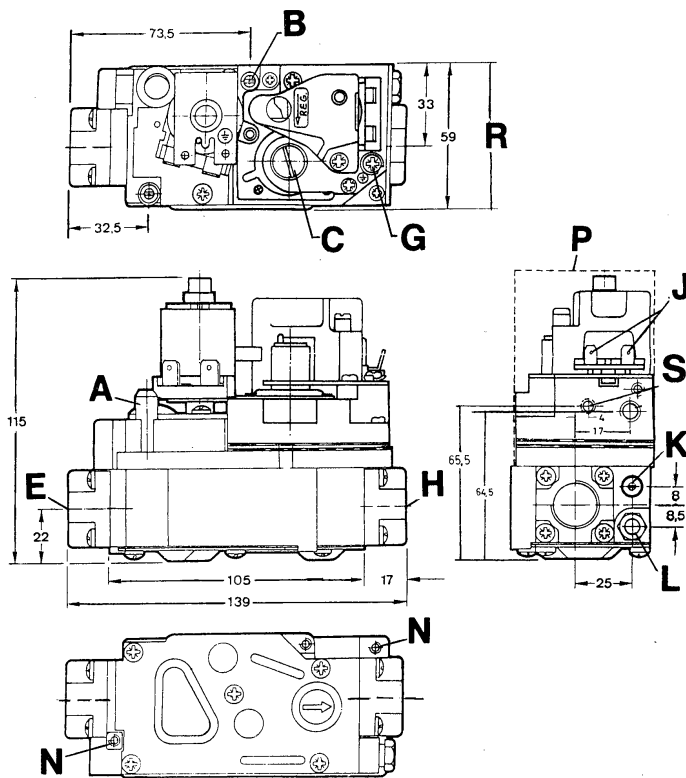

- A Inlet pressure tap
- B Pilot flow adjustment
- C Pressure flow adjustment
- D Throttle flow adjustment
- E Inlet
- G Earth screw
- H outlet
- J 6,3 mm AMP terminals
- K Outlet pressure tap
- L Pilot outlet *
- N Mounting holes M4 (2x)
- P Cover
- R 63 mm with cover
- S Pressure feedback connection

* for VR4700/VR8700

Fig. 3.

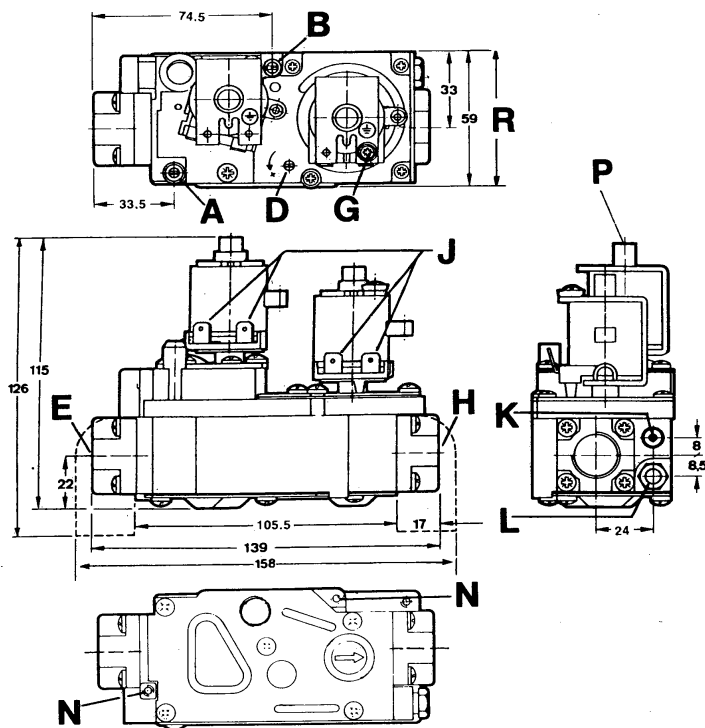

- A Inlet pressure tap
- B Pilot flow adjustment
- C Pressure flow adjustment
- D Throttle flow adjustment
- E Inlet
- G Earth screw
- H outlet
- J 6,3 mm AMP terminals
- K Outlet pressure tap
- L Pilot outlet *
- N Mounting holes M4 (2x)
- P Cover
- R 63 mm with cover
- S Pressure feedback connection

* for VR4700/VR8700

Fig. 4.

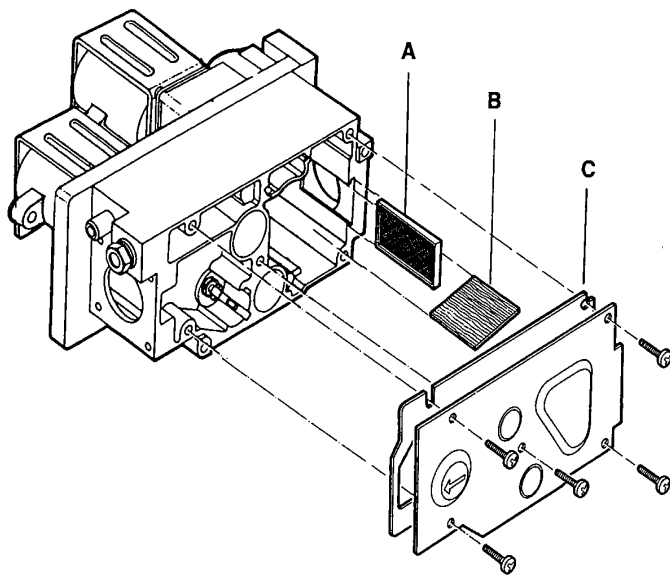

- A Screen
- B Pilot filter *
- C Gasket

* for VR4700/VR8700

Fig. 5.

Honeywell

Home and Building Control
Combustion Control Center Europe
Honeywell BV
Phileas Foggstraat 7
7821 AJ Emmen
The Netherlands
Tel.: +31 (-)591 695911
Fax: +31 (-) 591 695200
<http://europe.hbc.honeywell.com>